

CONCRETE EQUIPMENT



OMNIMAQ



A FERREYCORP COMPANY

SMALL CONCRETE MIXER

CARMIX ONE

TECHNICAL FEATURES

DRUM CAPACITY	370 gal
CONCRETE DRUM OUTPUT	1.3 yd ³ per cycle
PERKINS STAGE V	Tier 4F 403J-E17T Turbo-diesel, 4 cylinders, 36 Kw (48 Hp).
ADDITIONALS	REVERSIBLE DRIVING SEATS

DIMENSIONS

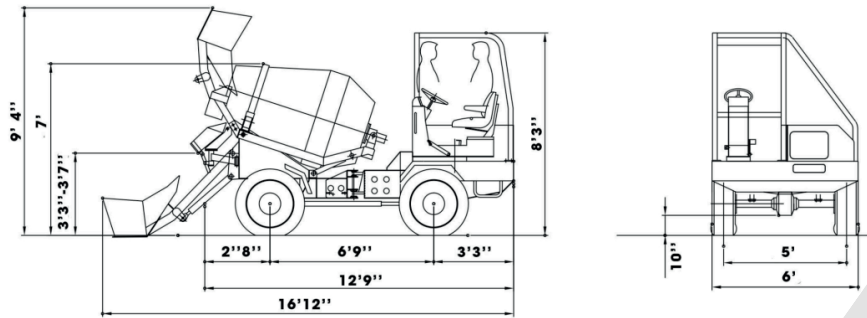

Illustrative image. Specifications may vary.

OFF ROAD MOBILE BATCHING PLANT

CARMIX 2.5TT

TECHNICAL FEATURES

DRUM CAPACITY

911 gal

CONCRETE DRUM OUTPUT

3.3 yd³ per cycle

PERKINS STAGE V

Tier 4F 904J-E36TA Turbo-diesel,
55,4 Kw (74 Hp).

ADDITIONALS

Load Cells electronic weighing
system/Articulated loader with
hydraulic door

DIMENSIONS

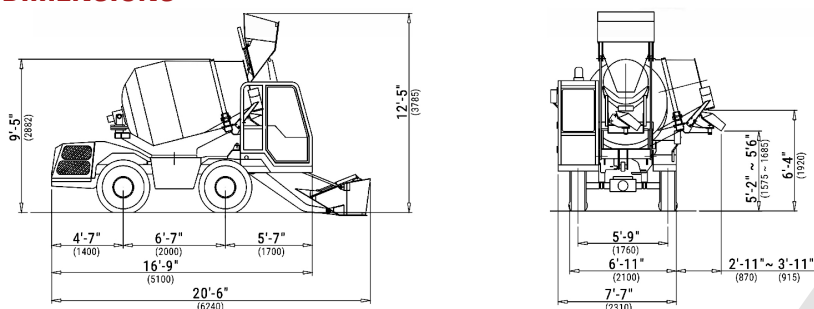

Illustrative image. Specifications may vary.

OFF ROAD MOBILE BATCHING PLANT

CARMIX 3500TC

TECHNICAL FEATURES

DRUM CAPACITY

1,281 gal

CONCRETE DRUM PUTOUT

4.6 yd³ per cycle

PERKINS STAGE V

Tier 4F 904J-E36TA Turbo-diesel,
90 Kw (120 Hp).

ADDITIONALS

All hydraulic functions of shovel
controlled by a single – fully servo
controlled Joystick

DIMENSIONS

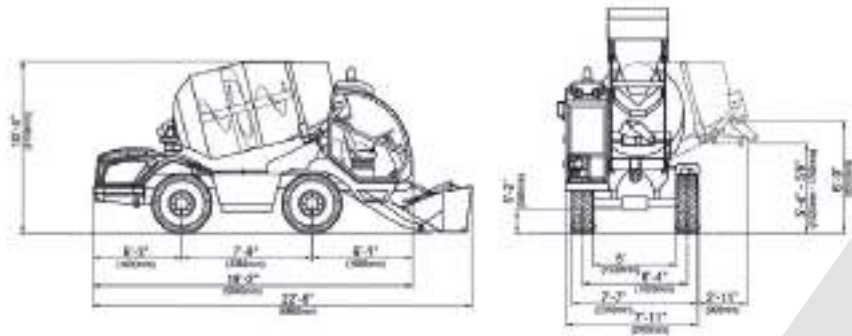

Illustrative image. Specifications may vary.

BLEND MODEL

E015

TECHNICAL FEATURES

AGGREGATES	4.6 yd ³
CEMENT	1.4 yd ³
WATER	145 gal
EMULSION	80 gal (opt.)
ADMIXTURES	3x11 gal (opt.)
OUTPUT	≤46 yd ³ /h
POWER*	27Kw PTO
EMPTY WEIGHT	3.700 Lb - 3.020 Lb
DIMENSIONS	11.7 x 6.5 x 4.7 ft



STANDALONE VERSION: CAN OPERATE WITH OR WITHOUT A TRUCK. TRUCK NOT INCLUDED.

Illustrative image. Specifications may vary.

BLEND MODEL

E050

TECHNICAL FEATURES

AGGREGATES	13 yd ³
CEMENT	4.2 yd ³
WATER	500/1000 gal (opt.)
EMULSION	160 gal (opt.)
ADMIXTURES	3x11 gal (opt.)
OUTPUT	≤65 yd ³ /h
POWER*	44Kw PTO
EMPTY WEIGHT	8.050 Lb - 7.100 Lb
DIMENSIONS	18.5 x 7.4 x 7.5 ft



STANDALONE VERSION: CAN OPERATE WITH OR WITHOUT A TRUCK. TRUCK NOT INCLUDED.

Illustrative image. Specifications may vary.

BLEND MODEL

SEVENTY

TECHNICAL FEATURES

AGGREGATES	16 yd ³
CEMENT	4.2 yd ³
WATER	500/1000 gal (opt.)
EMULSION	160 gal (opt.)
ADMIXTURES	3x11 gal (opt.)
OUTPUT	≤65 yd ³ /h
POWER*	44Kw PTO
EMPTY WEIGHT	8.200 Lb - 7.400 Lb
DIMENSIONS	20 x 7.4 x 7.5 ft



STANDALONE VERSION: CAN OPERATE WITH OR WITHOUT A TRUCK. TRUCK NOT INCLUDED.

Illustrative image. Specifications may vary.



A FERREYCORP COMPANY



(305) 522 - 5621



info@omnimaq.com



[Omnimaq](#)



[Omnimaq](#)



[Omnimaq](#)



12200 NW 25th St #103, Miami, FL 33182, United States



www.omnimaq.com